

**Problem 5.12-10** A flying buttress transmits a load  $P = 25$  kN, acting at an angle of  $60^\circ$  to the horizontal, to the top of a vertical buttress  $AB$  (see figure). The vertical buttress has height  $h = 5.0$  m and rectangular cross section of thickness  $t = 1.5$  m and width  $b = 1.0$  m (perpendicular to the plane of the figure). The stone used in the construction weighs  $\gamma = 26$  kN/m<sup>3</sup>.

What is the required weight  $W$  of the pedestal and statue above the vertical buttress (that is, above section  $A$ ) to avoid any tensile stresses in the vertical buttress?

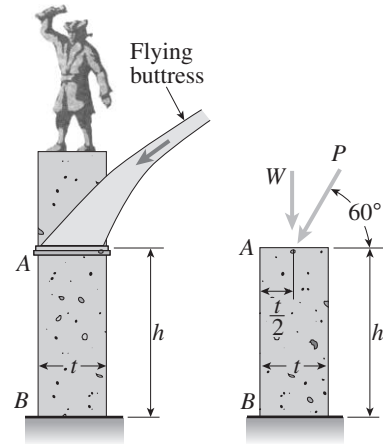

### Solution 5.12-10 Flying buttress

FREE-BODY DIAGRAM OF VERTICAL BUTTRESS

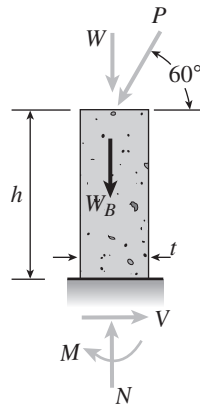

$$P = 25 \text{ kN}$$

$$h = 5.0 \text{ m}$$

$$t = 1.5 \text{ m}$$

$$b = \text{width of buttress perpendicular to the figure}$$

$$b = 1.0 \text{ m}$$

$$\gamma = 26 \text{ kN/m}^3$$

$$W_B = \text{weight of vertical buttress}$$

$$= bth\gamma$$

$$= 195 \text{ kN}$$

CROSS SECTION

$$A = bt = (1.0 \text{ m})(1.5 \text{ m}) = 1.5 \text{ m}^2$$

$$S = \frac{1}{6}bt^2 = \frac{1}{6}(1.0 \text{ m})(1.5 \text{ m})^2 = 0.375 \text{ m}^3$$

AT THE BASE

$$\begin{aligned} N &= W + W_B + P \sin 60^\circ \\ &= W + 195 \text{ kN} + (25 \text{ kN}) \sin 60^\circ \\ &= W + 216.651 \text{ kN} \end{aligned}$$

$$\begin{aligned} M &= (P \cos 60^\circ)h = (25 \text{ kN})(\cos 60^\circ)(5.0 \text{ m}) \\ &= 62.5 \text{ kN} \cdot \text{m} \end{aligned}$$

TENSILE STRESS (EQUAL TO ZERO)

$$\begin{aligned} \sigma_t &= -\frac{N}{A} + \frac{M}{S} \\ &= -\frac{W + 216.651 \text{ kN}}{1.5 \text{ m}^2} + \frac{62.5 \text{ kN} \cdot \text{m}}{0.375 \text{ m}^3} = 0 \end{aligned}$$

$$\text{or } -W - 216.651 \text{ kN} + 250 \text{ kN} = 0$$

$$W = 33.3 \text{ kN} \quad \leftarrow$$

**Problem 5.12-11** A plain concrete wall (i.e., a wall with no steel reinforcement) rests on a secure foundation and serves as a small dam on a creek (see figure). The height of the wall is  $h = 6.0$  ft and the thickness of the wall is  $t = 1.0$  ft.

(a) Determine the maximum tensile and compressive stresses  $\sigma_t$  and  $\sigma_c$ , respectively, at the base of the wall when the water level reaches the top ( $d = h$ ). Assume plain concrete has weight density  $\gamma_c = 145$  lb/ft<sup>3</sup>.

(b) Determine the maximum permissible depth  $d_{\max}$  of the water if there is to be no tension in the concrete.

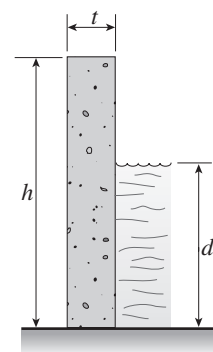

## Solution 5.12-11 Concrete wall

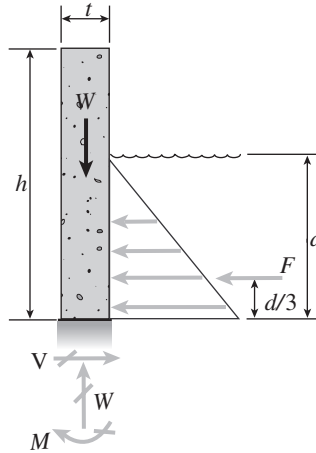

- $h$  = height of wall  
 $t$  = thickness of wall  
 $b$  = width of wall (perpendicular to the figure)  
 $\gamma_c$  = weight density of concrete  
 $\gamma_w$  = weight density of water  
 $d$  = depth of water  
 $W$  = weight of wall  
 $W = bht\gamma_c$   
 $F$  = resultant force for the water pressure

$$\text{MAXIMUM WATER PRESSURE} = \gamma_w d$$

$$F = \frac{1}{2}(d)(\gamma_w d)(b) = \frac{1}{2}bd^2\gamma_w$$

$$M = F\left(\frac{d}{3}\right) = \frac{1}{6}bd^3\gamma_w$$

$$A = bt \quad S = \frac{1}{6}bt^2$$

STRESSES AT THE BASE OF THE WALL  
 ( $d$  = DEPTH OF WATER)

$$\sigma_t = -\frac{W}{A} + \frac{M}{S} = -h\gamma_c + \frac{d^3\gamma_w}{t^2} \quad \text{Eq. (1)}$$

$$\sigma_c = -\frac{W}{A} - \frac{M}{S} = -h\gamma_c - \frac{d^3\gamma_w}{t^2} \quad \text{Eq. (2)}$$

(a) STRESSES AT THE BASE WHEN  $d = h$

$$h = 6.0 \text{ ft} = 72 \text{ in.} \quad d = 72 \text{ in.}$$

$$t = 1.0 \text{ ft} = 12 \text{ in.}$$

$$\gamma_c = 145 \text{ lb/ft}^3 = \frac{145}{1728} \text{ lb/in.}^3$$

$$\gamma_w = 62.4 \text{ lb/ft}^3 = \frac{62.4}{1728} \text{ lb/in.}^3$$

Substitute numerical values into Eqs. (1) and (2):

$$\sigma_t = -6.042 \text{ psi} + 93.600 \text{ psi} = 87.6 \text{ psi} \quad \leftarrow$$

$$\sigma_c = -6.042 \text{ psi} - 93.600 \text{ psi} = -99.6 \text{ psi} \quad \leftarrow$$

(b) MAXIMUM DEPTH FOR NO TENSION

Set  $\sigma_t = 0$  in Eq. (1):

$$-h\gamma_c + \frac{d^3\gamma_w}{t^2} = 0 \quad d^3 = ht^2\left(\frac{\gamma_c}{\gamma_w}\right)$$

$$d^3 = (72 \text{ in.})(12 \text{ in.})^2\left(\frac{145}{62.4}\right) = 24,092 \text{ in.}^3$$

$$d_{\max} = 28.9 \text{ in.} \quad \leftarrow$$

## Eccentric Axial Loads

**Problem 5.12-12** A circular post and a rectangular post are each compressed by loads that produce a resultant force  $P$  acting at the edge of the cross section (see figure). The diameter of the circular post and the depth of the rectangular post are the same.

(a) For what width  $b$  of the rectangular post will the maximum tensile stresses be the same in both posts?

(b) Under the conditions described in part (a), which post has the larger compressive stress?

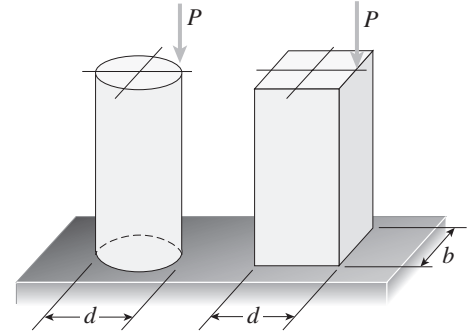
**Solution 5.12-12 Two posts in compression**

CIRCULAR POST

$$A = \frac{\pi d^2}{4} \quad S = \frac{\pi d^3}{32} \quad M = \frac{Pd}{2}$$

$$\text{Tension: } \sigma_t = -\frac{P}{A} + \frac{M}{S} = -\frac{4P}{\pi d^2} + \frac{16P}{\pi d^2} = \frac{12P}{\pi d^2}$$

$$\begin{aligned} \text{Compression: } \sigma_c &= -\frac{P}{A} - \frac{M}{S} = -\frac{4P}{\pi d^2} - \frac{16P}{\pi d^2} \\ &= -\frac{20P}{\pi d^2} \end{aligned}$$

RECTANGULAR POST

$$A = bd \quad S = \frac{bd^2}{6} \quad M = \frac{Pd}{2}$$

$$\text{Tension: } \sigma_t = -\frac{P}{A} + \frac{M}{S} = -\frac{P}{bd} + \frac{3P}{bd} = \frac{2P}{bd}$$

$$\text{Compression: } \sigma_c = -\frac{P}{A} - \frac{M}{S} = -\frac{P}{bd} - \frac{3P}{bd} = -\frac{4P}{bd}$$

EQUAL MAXIMUM TENSILE STRESSES

$$\frac{12P}{\pi d^2} = \frac{2P}{bd} \quad \text{or} \quad \frac{6}{\pi d} = \frac{1}{b} \quad (\text{Eq. 1})$$

(a) Determine the width  $b$  of the rectangular post

$$\text{From Eq. (1): } b = \frac{\pi d}{6} \quad \leftarrow$$

(b) Compressive stresses

$$\text{Circular post: } \sigma_c = -\frac{20P}{\pi d^2}$$

$$\begin{aligned} \text{Rectangular post: } \sigma_c &= -\frac{4P}{bd} = -\frac{4P}{(\pi d/6)d} \\ &= -\frac{24P}{\pi d^2} \end{aligned}$$

Rectangular post has the larger compressive stress.  $\leftarrow$ 

**Problem 5.12-13** Two cables, each carrying a tensile force  $P = 1200$  lb, are bolted to a block of steel (see figure). The block has thickness  $t = 1$  in. and width  $b = 3$  in.

(a) If the diameter  $d$  of the cable is 0.25 in., what are the maximum tensile and compressive stresses  $\sigma_t$  and  $\sigma_c$ , respectively, in the block?

(b) If the diameter of the cable is increased (without changing the force  $P$ ), what happens to the maximum tensile and compressive stresses?

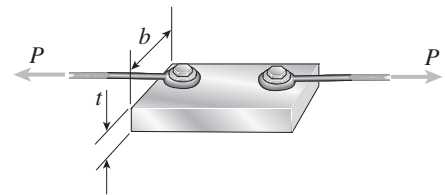

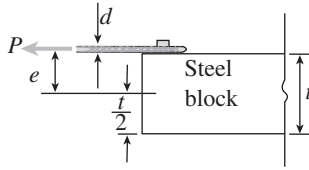
**Solution 5.12-13 Steel block loaded by cables**

$$P = 1200 \text{ lb} \quad d = 0.25 \text{ in.}$$

$$t = 1.0 \text{ in.} \quad e = \frac{t}{2} + \frac{d}{2} = 0.625 \text{ in.}$$

$b =$  width of block  
 $= 3.0 \text{ in.}$

CROSS SECTION OF BLOCK

$$A = bt = 3.0 \text{ in.}^2 \quad I = \frac{1}{12}bt^3 = 0.25 \text{ in.}^4$$

(a) MAXIMUM TENSILE STRESS (AT TOP OF BLOCK)

$$y = \frac{t}{2} = 0.5 \text{ in.}$$

$$\sigma_t = \frac{P}{A} + \frac{Pey}{I}$$

$$= \frac{1200 \text{ lb}}{3 \text{ in.}^2} + \frac{(1200 \text{ lb})(0.625 \text{ in.})(0.5 \text{ in.})}{0.25 \text{ in.}^4}$$

$$= 400 \text{ psi} + 1500 \text{ psi} = 1900 \text{ psi} \quad \leftarrow$$

MAXIMUM COMPRESSIVE STRESS (AT BOTTOM OF BLOCK)

$$y = -\frac{t}{2} = -0.5 \text{ in.}$$

$$\sigma_c = \frac{P}{A} + \frac{Pey}{I}$$

$$= \frac{1200 \text{ lb}}{3 \text{ in.}^2} + \frac{(1200 \text{ lb})(0.625 \text{ in.})(-0.5 \text{ in.})}{0.25 \text{ in.}^4}$$

$$= 400 \text{ psi} - 1500 \text{ psi} = -1100 \text{ psi} \quad \leftarrow$$

(b) If  $d$  IS INCREASED, the eccentricity  $e$  increases and both stresses increase in magnitude.

**Problem 5.12-14** A bar  $AB$  supports a load  $P$  acting at the centroid of the end cross section (see figure). In the middle region of the bar the cross-sectional area is reduced by removing one-half of the bar.

(a) If the end cross sections of the bar are square with sides of length  $b$ , what are the maximum tensile and compressive stresses  $\sigma_t$  and  $\sigma_c$ , respectively, at cross section  $mn$  within the reduced region?

(b) If the end cross sections are circular with diameter  $b$ , what are the maximum stresses  $\sigma_t$  and  $\sigma_c$ ?

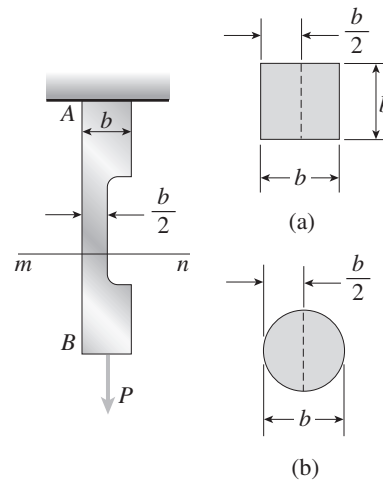

**Solution 5.12-14 Bar with reduced cross section**

(a) SQUARE BAR

Cross section  $mn$  is a rectangle.

$$A = (b)\left(\frac{b}{2}\right) = \frac{b^2}{2} \quad I = \frac{1}{12}(b)\left(\frac{b}{2}\right)^3 = \frac{b^4}{96}$$

$$M = P\left(\frac{b}{4}\right) \quad c = \frac{b}{4}$$

STRESSES

$$\sigma_t = \frac{P}{A} + \frac{Mc}{I} = \frac{2P}{b^2} + \frac{6P}{b^2} = \frac{8P}{b^2} \quad \leftarrow$$

$$\sigma_c = \frac{P}{A} - \frac{Mc}{I} = \frac{2P}{b^2} - \frac{6P}{b^2} = -\frac{4P}{b^2} \quad \leftarrow$$

(b) CIRCULAR BAR

Cross section  $mn$  is a semicircle

$$A = \frac{1}{2}\left(\frac{\pi b^2}{4}\right) = \frac{\pi b^2}{8} = 0.3927 b^2$$

From Appendix D, Case 10:

$$I = 0.1098\left(\frac{b}{2}\right)^4 = 0.006860 b^4$$

$$M = P\left(\frac{2b}{3\pi}\right) = 0.2122 Pb$$

FOR TENSION:

$$c_t = \frac{4r}{3\pi} = \frac{2b}{3\pi} = 0.2122 b$$

FOR COMPRESSION:

$$c_c = r - c_t = \frac{b}{2} - \frac{2b}{3\pi} = 0.2878 b$$

STRESSES

$$\begin{aligned} \sigma_t &= \frac{P}{A} + \frac{Mc_t}{I} = \frac{P}{0.3927 b^2} + \frac{(0.2122 Pb)(0.2122 b)}{0.006860 b^4} \\ &= 2.546 \frac{P}{b^2} + 6.564 \frac{P}{b^2} = 9.11 \frac{P}{b^2} \quad \leftarrow \end{aligned}$$

$$\begin{aligned} \sigma_c &= \frac{P}{A} - \frac{Mc_c}{I} = \frac{P}{0.3927 b^2} - \frac{(0.2122 Pb)(0.2878 b)}{0.006860 b^4} \\ &= 2.546 \frac{P}{b^2} - 8.903 \frac{P}{b^2} = -6.36 \frac{P}{b^2} \quad \leftarrow \end{aligned}$$

**Problem 5.12-15** A short column constructed of a W 10 × 30 wide-flange shape is subjected to a resultant compressive load  $P = 12$  k having its line of action at the midpoint of one flange (see figure).

(a) Determine the maximum tensile and compressive stresses  $\sigma_t$  and  $\sigma_c$ , respectively, in the column.

(b) Locate the neutral axis under this loading condition.

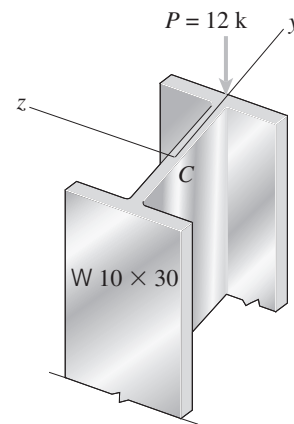

## Solution 5.12-15 Column of wide-flange shape

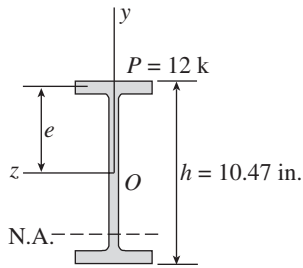

$$\begin{aligned}
 W 10 \times 30 \quad A &= 8.84 \text{ in.}^2 \\
 I &= 170 \text{ in.}^4 \quad t_f = 0.510 \text{ in.} \\
 e &= \frac{h}{2} - \frac{t_f}{2} = 4.98 \text{ in.}
 \end{aligned}$$

(a) MAXIMUM STRESSES

$$\begin{aligned}
 \sigma_t &= -\frac{P}{A} + \frac{Pe(h/2)}{I} = -1357 \text{ psi} + 1840 \text{ psi} \\
 &= 480 \text{ psi} \quad \leftarrow
 \end{aligned}$$

$$\begin{aligned}
 \sigma_c &= -\frac{P}{A} - \frac{Pe(h/2)}{I} = -1357 \text{ psi} - 1840 \text{ psi} \\
 &= -3200 \text{ psi} \quad \leftarrow
 \end{aligned}$$

(b) NEUTRAL AXIS (SEE FIGURE)

$$y_0 = -\frac{I}{Ae} = -3.86 \text{ in.} \quad \leftarrow$$

**Problem 5.12-16** A short column of wide-flange shape is subjected to a compressive load that produces a resultant force  $P = 60 \text{ kN}$  acting at the midpoint of one flange (see figure).

- (a) Determine the maximum tensile and compressive stresses  $\sigma_t$  and  $\sigma_c$ , respectively, in the column.  
 (b) Locate the neutral axis under this loading condition.

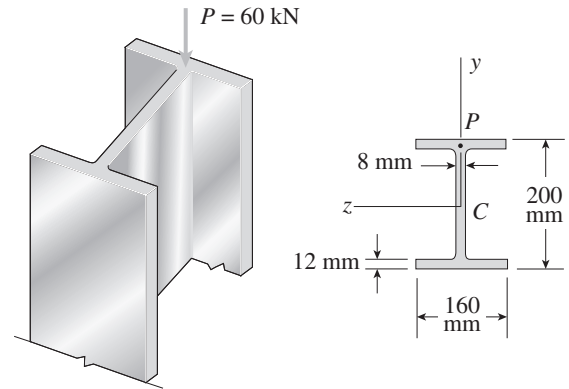

## Solution 5.12-16 Column of wide-flange shape

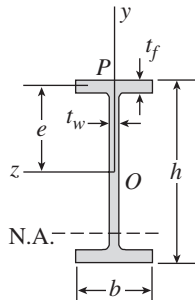

$$\begin{aligned}
 b &= 160 \text{ mm} \quad t_w = 8 \text{ mm} \\
 h &= 200 \text{ mm} \quad t_f = 12 \text{ mm} \\
 P &= 60 \text{ kN} \quad e = \frac{h}{2} - \frac{t_f}{2} = 94 \text{ mm} \\
 A &= 2bt_f + (h - 2t_f)t_w = 5248 \text{ mm}^2 \\
 I &= \frac{1}{12}bh^3 - \frac{1}{12}(b - t_w)(h - 2t_f)^3 \\
 &= 37.611 \times 10^6 \text{ mm}^4
 \end{aligned}$$

(a) MAXIMUM STRESSES

$$\begin{aligned}
 \sigma_t &= -\frac{P}{A} + \frac{Pe(h/2)}{I} \\
 &= -\frac{60 \text{ kN}}{5248 \text{ mm}^2} + \frac{(60 \text{ kN})(94 \text{ mm})(100 \text{ mm})}{37.611 \times 10^6 \text{ mm}^4} \\
 &= -11.43 \text{ MPa} + 15.00 \text{ MPa} \\
 &= 3.57 \text{ MPa} \quad \leftarrow
 \end{aligned}$$

$$\begin{aligned}
 \sigma_c &= -11.43 \text{ MPa} - 15.00 \text{ MPa} \\
 &= -26.4 \text{ MPa} \quad \leftarrow
 \end{aligned}$$

(b) NEUTRAL AXIS (SEE FIGURE)

$$\begin{aligned}
 y_0 &= -\frac{I}{Ae} = -\frac{37.611 \times 10^6 \text{ mm}^4}{(5248 \text{ mm}^2)(94 \text{ mm})} \\
 &= -76.2 \text{ mm} \quad \leftarrow
 \end{aligned}$$

**Problem 5.12-17** A tension member constructed of an  $L 4 \times 4 \times \frac{3}{4}$  inch angle section (see Appendix E) is subjected to a tensile load  $P = 15$  kips that acts through the point where the midlines of the legs intersect (see figure).

Determine the maximum tensile stress  $\sigma_t$  in the angle section.

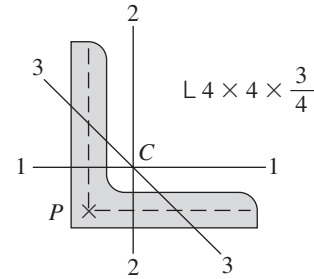

**Solution 5.12-17** Angle section in tension

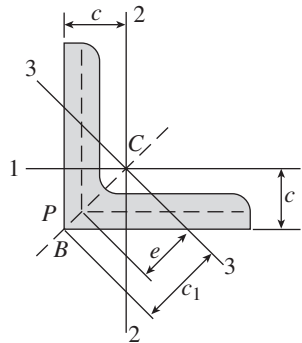

Bending occurs about axis 3-3.

$$L 4 \times 4 \times \frac{3}{4}$$

$$A = 5.44 \text{ in.}^2 \quad t = \text{thickness of legs}$$

$$c = 1.27 \text{ in.} \quad = 0.75 \text{ in.}$$

$$e = \text{eccentricity of load } P$$

$$= \left( c - \frac{t}{2} \right) \sqrt{2}$$

$$= (1.27 - 0.375) \sqrt{2}$$

$$= 1.266 \text{ in.}$$

$$P = 15 \text{ k (tensile load)}$$

$$c_1 = \text{distance from centroid } C \text{ to corner } B \text{ of angle}$$

$$= c \sqrt{2} = (1.27 \text{ in.}) \sqrt{2} = 1.796 \text{ in.}$$

$$I_3 = A r_{\min}^2 \quad (\text{see Table E-4})$$

$$r_{\min} = 0.778 \text{ in.}$$

$$I_3 = (5.44 \text{ in.}^2)(0.778 \text{ in.})^2 = 3.293 \text{ in.}^4$$

$$M = P e = (15 \text{ k})(1.266 \text{ in.}) = 18.94 \text{ k-in.}$$

MAXIMUM TENSILE STRESS

Maximum tensile stress occurs at corner  $B$ .

$$\begin{aligned} \sigma_t &= \frac{P}{A} + \frac{M c_1}{I_3} \\ &= \frac{15 \text{ k}}{5.44 \text{ in.}^2} + \frac{(18.94 \text{ k-in.})(1.796 \text{ in.})}{3.293 \text{ in.}^4} \\ &= 2.76 \text{ ksi} + 10.36 \text{ ksi} \\ &= 13.1 \text{ ksi} \quad \leftarrow \end{aligned}$$

**Problem 5.12-18** A short length of a C 8×11.5 channel is subjected to an axial compressive force  $P$  that has its line of action through the midpoint of the web of the channel (see figure).

(a) Determine the equation of the neutral axis under this loading condition.

(b) If the allowable stresses in tension and compression are 10,000 psi and 8,000 psi, respectively, find the maximum permissible load  $P_{\max}$ .

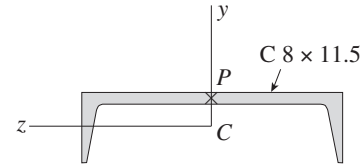

**Solution 5.12-18 Channel in compression**

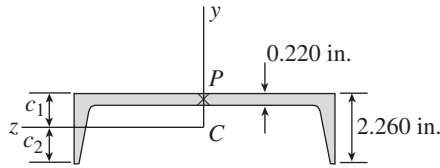

C 8 × 11.5

$$A = 3.38 \text{ in.}^2 \quad h = 2.260 \text{ in.} \quad t_w = 0.220 \text{ in.}$$

$$I_z = 1.32 \text{ in.}^4 \quad c_1 = 0.571 \text{ in.} \quad c_2 = 1.689 \text{ in.}$$

ECCENTRICITY OF THE LOAD

$$e = c_1 - \frac{t_w}{2} = 0.571 - 0.110 = 0.461 \text{ in.}$$

(a) LOCATION OF THE NEUTRAL AXIS

$$y_0 = -\frac{I}{Ae} = -\frac{1.32 \text{ in.}^4}{(3.38 \text{ in.}^2)(0.461 \text{ in.})}$$

$$= -0.847 \text{ in.} \quad \leftarrow$$

(b) MAXIMUM LOAD BASED UPON TENSILE STRESS

$$\sigma_{\text{allow}} = 10,000 \text{ psi} \quad (P = \text{pounds})$$

$$\sigma_t = -\frac{P}{A} + \frac{Pec_2}{I}$$

$$= -\frac{P}{3.38 \text{ in.}^2} + \frac{P(0.461 \text{ in.})(1.689 \text{ in.})}{1.32 \text{ in.}^4}$$

$$10,000 = -\frac{P}{3.38} + \frac{P}{1.695} = 0.2941 P$$

$$P = 34,000 \text{ lb} = 34 \text{ k}$$

MAXIMUM LOAD BASED UPON COMPRESSIVE STRESS

$$\sigma_{\text{allow}} = 8000 \text{ psi} \quad (P = \text{pounds})$$

$$\sigma_c = -\frac{P}{A} - \frac{Pec_1}{I}$$

$$= -\frac{P}{3.38 \text{ in.}^2} - \frac{P(0.461 \text{ in.})(0.571 \text{ in.})}{1.32 \text{ in.}^4}$$

$$8000 = \frac{P}{3.38} - \frac{P}{5.015} = 0.4953 P$$

$$P = 16,200 \text{ lb} = 16.2 \text{ k}$$

COMPRESSION GOVERNS.  $P_{\max} = 16.2 \text{ k} \quad \leftarrow$

## Stress Concentrations

The problems for Section 5.13 are to be solved considering the stress-concentration factors.

**Problem 5.13-1** The beams shown in the figure are subjected to bending moments  $M = 2100$  lb-in. Each beam has a rectangular cross section with height  $h = 1.5$  in. and width  $b = 0.375$  in. (perpendicular to the plane of the figure).

(a) For the beam with a hole at midheight, determine the maximum stresses for hole diameters  $d = 0.25, 0.50, 0.75,$  and  $1.00$  in.

(b) For the beam with two identical notches (inside height  $h_1 = 1.25$  in.), determine the maximum stresses for notch radii  $R = 0.05, 0.10, 0.15,$  and  $0.20$  in.

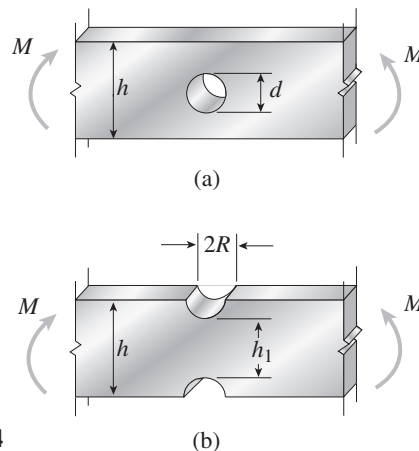

Probs. 5.13-1 through 5.13-4

## Solution 5.13-1

$$M = 2100 \text{ lb-in.} \quad h = 1.5 \text{ in.} \quad b = 0.375 \text{ in.}$$

(a) BEAM WITH A HOLE

$$\frac{d}{h} \leq \frac{1}{2} \quad \text{Eq. (5-57):} \quad \sigma_C = \frac{6Mh}{b(h^3 - d^3)} = \frac{50,400}{3.375 - d^3} \quad (1)$$

$$\frac{d}{h} \geq \frac{1}{2} \quad \text{Eq. (5-56):} \quad \sigma_B = \frac{12Md}{b(h^3 - d^3)} = \frac{67,200d}{3.375 - d^3} \quad (2)$$

$d$ (in.)	$\frac{d}{h}$	$\sigma_C$ Eq.(1) (psi)	$\sigma_B$ Eq.(2) (psi)	$\sigma_{\max}$ (psi)
0.25	0.1667	15,000	—	15,000
0.50	0.3333	15,500	—	15,500
0.75	0.5000	17,100	17,100	17,100
1.00	0.6667	—	28,300	28,300

Note: The larger the hole, the larger the stress.

(b) BEAM WITH NOTCHES

$$h_1 = 1.25 \text{ in.} \quad \frac{h}{h_1} = \frac{1.5 \text{ in.}}{1.25 \text{ in.}} = 1.2$$

Eq. (5-58):

$$\sigma_{\text{nom}} = \frac{6M}{bh_1^2} = 21,500 \text{ psi}$$

$R$ (in.)	$\frac{R}{h_1}$	$K$ (Fig. 5-50)	$\sigma_{\max} = K\sigma_{\text{nom}}$ (psi)
0.05	0.04	3.0	65,000
0.10	0.08	2.3	49,000
0.15	0.12	2.1	45,000
0.20	0.16	1.9	41,000

Note: The larger the notch radius, the smaller the stress.

**Problem 5.13-2** The beams shown in the figure are subjected to bending moments  $M = 250 \text{ N} \cdot \text{m}$ . Each beam has a rectangular cross section with height  $h = 44 \text{ mm}$  and width  $b = 10 \text{ mm}$  (perpendicular to the plane of the figure).

(a) For the beam with a hole at midheight, determine the maximum stresses for hole diameters  $d = 10, 16, 22,$  and  $28 \text{ mm}$ .

(b) For the beam with two identical notches (inside height  $h_1 = 40 \text{ mm}$ ), determine the maximum stresses for notch radii  $R = 2, 4, 6,$  and  $8 \text{ mm}$ .

**Solution 5.13-2**

$$M = 250 \text{ N} \cdot \text{m} \quad h = 44 \text{ mm} \quad b = 10 \text{ mm}$$

(a) BEAM WITH A HOLE

$$\frac{d}{h} \leq \frac{1}{2} \quad \text{Eq. (5-57):} \quad \sigma_C = \frac{6Mh}{b(h^3 - d^3)}$$

$$= \frac{6.6 \times 10^6}{85,180 - d^3} \text{ MPa} \quad (1)$$

$$\frac{d}{h} \geq \frac{1}{2} \quad \text{Eq. (5-56):} \quad \sigma_B = \frac{12Md}{b(h^3 - d^3)}$$

$$= \frac{300 \times 10^3 d}{85,180 - d^3} \text{ MPa} \quad (2)$$

$d$ (mm)	$\frac{d}{h}$	$\sigma_C$ Eq.(1) (MPa)	$\sigma_B$ Eq.(2) (MPa)	$\sigma_{\max}$ (MPa)
10	0.227	78	—	78
16	0.364	81	—	81
22	0.500	89	89	89
28	0.636	—	133	133

Note: The larger the hole, the larger the stress.

(b) BEAM WITH NOTCHES

$$h_1 = 40 \text{ mm} \quad \frac{h}{h_1} = \frac{44 \text{ mm}}{40 \text{ mm}} = 1.1$$

$$\text{Eq. (5-58): } \sigma_{\text{nom}} = \frac{6M}{bh_1^2} = 93.8 \text{ MPa}$$

$$\sigma_{\max} = K\sigma_{\text{nom}}$$

$R$ (mm)	$\frac{R}{h_1}$	$K$ (Fig. 5-50)	$\sigma_{\max}$ (MPa)
2	0.05	2.6	240
4	0.10	2.1	200
6	0.15	1.8	170
8	0.20	1.7	160

Note: The larger the notch radius, the smaller the stress.

**Problem 5.13-3** A rectangular beam with semicircular notches, as shown in part (b) of the figure, has dimensions  $h = 0.88 \text{ in.}$  and  $h_1 = 0.80 \text{ in.}$  The maximum allowable bending stress in the metal beam is  $\sigma_{\max} = 60 \text{ ksi}$ , and the bending moment is  $M = 600 \text{ lb-in.}$

Determine the minimum permissible width  $b_{\min}$  of the beam.

**Solution 5.13-3 Beam with semicircular notches**

$$h = 0.88 \text{ in.} \quad h_1 = 0.80 \text{ in.}$$

$$\sigma_{\max} = 60 \text{ ksi} \quad M = 600 \text{ lb-in.}$$

$$h = h_1 + 2R \quad R = \frac{1}{2}(h - h_1) = 0.04 \text{ in.}$$

$$\frac{R}{h_1} = \frac{0.04 \text{ in.}}{0.80 \text{ in.}} = 0.05$$

From Fig. 5-50:  $K \approx 2.57$

$$\sigma_{\max} = K\sigma_{\text{nom}} = K\left(\frac{6M}{bh_1^2}\right)$$

$$60 \text{ ksi} = 2.57 \left[ \frac{6(600 \text{ lb-in.})}{b(0.80 \text{ in.})^2} \right]$$

Solve for  $b$ :

$$b_{\min} \approx 0.24 \text{ in.} \quad \leftarrow$$

**Problem 5.13-4** A rectangular beam with semicircular notches, as shown in part (b) of the figure, has dimensions  $h = 120$  mm and  $h_1 = 100$  mm. The maximum allowable bending stress in the plastic beam is  $\sigma_{\max} = 6$  MPa, and the bending moment is  $M = 150$  N · m. Determine the minimum permissible width  $b_{\min}$  of the beam.

**Solution 5.13-4 Beam with semicircular notches**

$$h = 120 \text{ mm} \quad h_1 = 100 \text{ mm}$$

$$\sigma_{\max} = 6 \text{ MPa} \quad M = 150 \text{ N} \cdot \text{m}$$

$$h = h_1 + 2R \quad R = \frac{1}{2}(h - h_1) = 10 \text{ mm}$$

$$\frac{R}{h_1} = \frac{10 \text{ mm}}{100 \text{ mm}} = 0.10$$

From Fig. 5-50:  $K \approx 2.20$

$$\sigma_{\max} = K\sigma_{\text{nom}} = K\left(\frac{6M}{bh_1^2}\right)$$

$$6 \text{ MPa} = (2.20) \left[ \frac{6(150 \text{ N} \cdot \text{m})}{b(100 \text{ mm})^2} \right]$$

Solve for  $b$ :

$$b_{\min} \approx 33 \text{ mm} \quad \leftarrow$$

**Problem 5.13-5** A rectangular beam with notches and a hole (see figure) has dimensions  $h = 5.5$  in.,  $h_1 = 5$  in., and width  $b = 1.6$  in. The beam is subjected to a bending moment  $M = 130$  k-in., and the maximum allowable bending stress in the material (steel) is  $\sigma_{\max} = 42,000$  psi.

(a) What is the smallest radius  $R_{\min}$  that should be used in the notches?

(b) What is the diameter  $d_{\max}$  of the largest hole that should be drilled at the midheight of the beam?

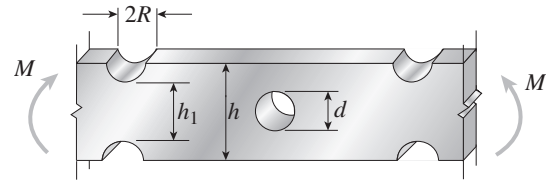

**Solution 5.13-5 Beam with notches and a hole**

$$h = 5.5 \text{ in.} \quad h_1 = 5 \text{ in.} \quad b = 1.6 \text{ in.}$$

$$M = 130 \text{ k-in.} \quad \sigma_{\max} = 42,000 \text{ psi}$$

(a) MINIMUM NOTCH RADIUS

$$\frac{h}{h_1} = \frac{5.5 \text{ in.}}{5 \text{ in.}} = 1.1$$

$$\sigma_{\text{nom}} = \frac{6M}{bh_1^2} = 19,500 \text{ psi}$$

$$K = \frac{\sigma_{\max}}{\sigma_{\text{nom}}} = \frac{42,000 \text{ psi}}{19,500 \text{ psi}} = 2.15$$

From Fig. 5-50, with  $K = 2.15$  and  $\frac{h}{h_1} = 1.1$ , we get

$$\frac{R}{h_1} \approx 0.090$$

$$\therefore R_{\min} \approx 0.090h_1 = 0.45 \text{ in.} \quad \leftarrow$$

(b) LARGEST HOLE DIAMETER

Assume  $\frac{d}{h} > \frac{1}{2}$  and use Eq. (5-56).

$$\sigma_B = \frac{12Md}{b(h^3 - d^3)}$$

$$42,000 \text{ psi} = \frac{12(130 \text{ k-in.})d}{(1.6 \text{ in.})[(5.5 \text{ in.})^3 - d^3]} \quad \text{or}$$

$$d^3 + 23.21d - 166.4 = 0$$

Solve numerically:

$$d_{\max} = 4.13 \text{ in.} \quad \leftarrow$$